

Instructions

Body Mount and Radiator Mount Bushings

Application - Chevrolet K10 4WD

N.B: This instruction sheet should be used in conjunction with the workshop manual and proper safety procedures followed.

Note: Any rusted nuts or bolts will require lubricant prior to disassemble.

When removing each mount, be sure to note each location on vehicle.
Also, any existing shims will need to be re-used in their respective point

1. Loosen all nuts, but only remove nuts from one side of vehicle at a time.

Be careful of fan shroud and other components while lifting.
A hydraulic jack and wood may be used to lift the body.

2. Replace 1 mount at a time, but do not tighten.

3. Once all mounts are replaced, confirm body is straight/aligned - tighten all nuts/bolts to Manufacturers specifications.

4. It is recommended all hardware is re-checked after 500kms/miles travelled.

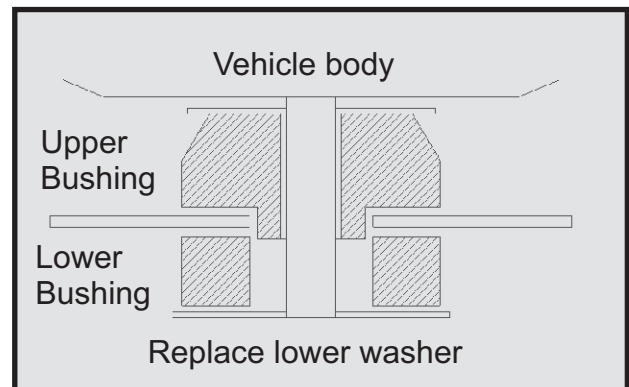

← Front

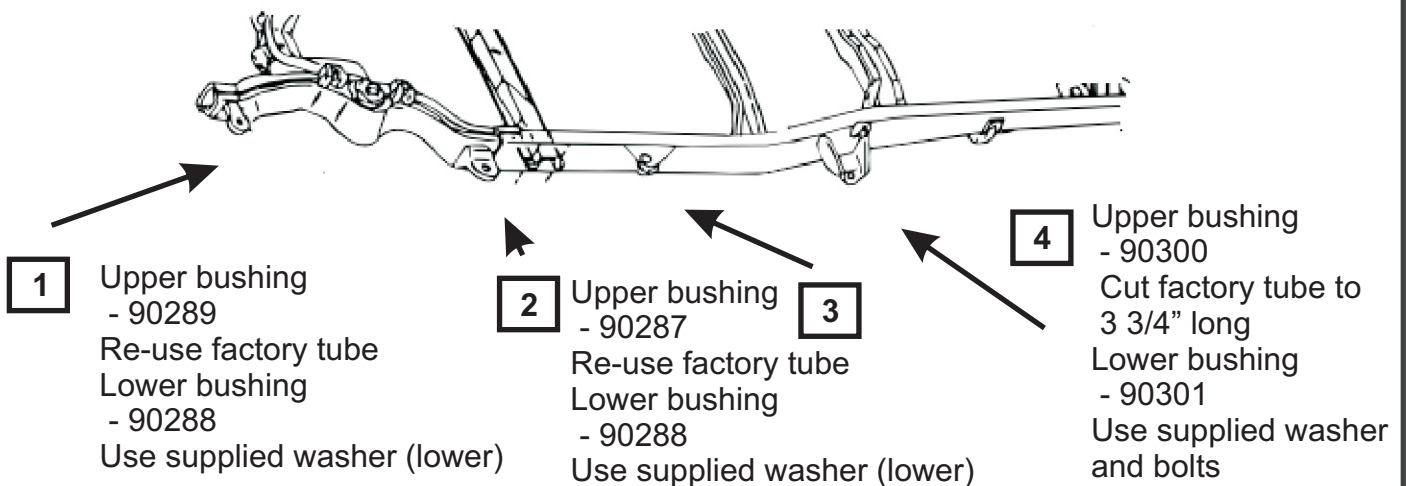

N.B: It is recommended that a licenced workshop or tradesperson carry out the above procedure and that workshop manual and relevant safety procedures are followed in addition to the above.